

# Operating Manual

**Process titrator  
for Residual Hardness of water  
AQUACON RH  
(PC – Cabinet)**

---

Seb.2011

Fillerkampsweg 1 – 5 • 31832 Springe OT Eldagsen • Tel.: 05044/887-0 (Fax: -99)

E-Mail: [info@iotronic.de](mailto:info@iotronic.de)

Internet: <http://www.iotronic.de>





**iotronic**  
ELEKTROGERÄTEBAU GMBH





<b>1</b>	<b>GENERAL GUIDELINES FOR SAFETY</b>	<b>3</b>
<b>2</b>	<b>PRINCIPLE OF OPERATION</b>	<b>4</b>
<b>3</b>	<b>DESCRIPTION OF THE PROCESS TITRATOR</b>	<b>4</b>
3.1	Analytical Part	7
3.2	Measurement and Control	7
3.3	Operation and Measurement Security	7
3.4	Automatic Operation	8
3.5	Manual Operation	9
3.6	Display/Set Parameters	10
3.6.1	Limit Value	11
3.6.2	Alarm value	11
3.6.3	Analog Output setting (mode, start value and end value)	12
3.6.4	Sample Interval	12
3.6.5	Titer/Calibration Factor	12
3.6.6	Rinsing Time	12
3.6.7	Reagent Volume	12
<b>4</b>	<b>SWITCHING FUNCTIONS OF THE PROCESS TITRATOR</b>	<b>13</b>
4.1	External Switching	13
4.2	Display in the standby mode:	13
4.3	Analysis state relay	13
4.4	Limit Value Relay	14
4.5	Alarm Limit Relay	14
4.6	Current Output	14
<b>5</b>	<b>START-UP AND MAINTENANCE INSTRUCTIONS</b>	<b>15</b>

5.1	Connection of sample water	15
5.2	Connection of reagent, bleeding of pumps and tubes	15
5.3	Replenishment of Reagent	15
5.4	Changing of Tube box	15
5.5	Recalibration of the Process analyzer	16
5.6	Maintenance interval	16
5.7	Shut down procedure	16
<b>6</b>	<b>ALARM MESSAGES</b>	<b>17</b>
<b>7</b>	<b>TECHNICAL DATA</b>	<b>17</b>
<b>8</b>	<b>SPECIFICATIONS</b>	<b>18</b>
<b>9</b>	<b>CONNECTION DIAGRAM</b>	<b>18</b>
9.1	Set 0/4 - 20 mA-Output	18
9.2	Connections	19
9.3	Installation	20
<b>10</b>	<b>APPENDIX</b>	<b>21</b>
10.1	Analysis cycle	21
10.2	Spare part and consumable item list	22
<b>11</b>	<b>TROUBLESHOOTING GUIDE</b>	<b>23</b>

## 1 General Guidelines for Safety

	<b>WARNING</b>	<b>(Nonobservance or misapplication of the contents of the „Warning“ section could lead to serious accident, including death or injury)</b>
<b>Turn off the power supply.</b>		
Working without disconnecting the power supply may cause an electrical shock. Before engaging upon any working procedures make sure to disconnect the power supply.		
		
Electrical Shock		
<b>No remodelling !</b>		
Never remodel an analyser. Otherwise, a serious accident may result. IOTRONIC will not be responsible for any accident or damage of any kind which is caused by the user remodelling the analyser.		
		
No Remodeling		
<b>Operating site must be free of water and humidity</b>		
The analytical instrument is not designed to be water-proof or dust-proof. The use of the analyser in places where water splashes or humidity is high may result in an electrical shock or short-circuit.		
		
Prohibited		

	<b>CAUTION !</b>	<b>(Nonobservance or misapplication of the contents of the „Caution“ section could lead to serious physical injury to the user or serious damage to the product.)</b>
<b>Specified power only</b>		
Do not operate the analyser on voltage which is not specified on the label on the right side of the transmitter housing. Failure to do so can result in damage or fire. Only the specified power level is to be applied.		
		
Caution		
<b>Do not damage or change power cable !</b>		
Do not scratch, damage, process, or pull the power cable forcibly. Nonobservance could cause a fire or an electrical shock.		
		
Caution		

### **Notes on operation**

- Dropping the device or subjecting it to strong impacts may result in faulty performance. Handle the analyser with care.
- Select an installation site convenient for future maintenance and inspection, and fix the device carefully so that it is free of vibrations.

## **2 Principle of Operation**

The process titrator for residual water hardness AQUACON RH performs a discontinuous complexometric determination of hardness (total hardness) on the sample being measured. The entire operation, which includes filling, draining and rinsing of the measuring cuvette, is controlled by a microprocessor.

A proprietary single-component reagent (indicator and titrant) is delivered via a high-precision peristaltic pump and mixed with the sample in the measuring chamber. The titration end-point is reached when the indicator colour changes from red to blue. This colour change is measured using a monochromatic photometric detection system. The quantity of reagent required to reach the colour change is determined from the number of pump revolutions required during the titration.

The result may be displayed on the touchscreen in a variety of units eg. German degrees of hardness, °dH, ppm CaCO<sub>3</sub>, mmol/l alkaline earth ions as selected by the customer (1 °dH = 0,18 mmol/l alkaline earth ions, or = 17,8 ppm CaCO<sub>3</sub>).

## **3 Description of the Process titrator**

The process titrator AQUACON RH is delivered completely mounted in a polycarbonate wall cabinet, ready for installation. This includes all the components for sample and drain connection, measurement chamber, reagent pump, display and connections for remote display and control. All functions of the process titrator can be operated via touchscreen.

View of the process titrator AQUACON RH

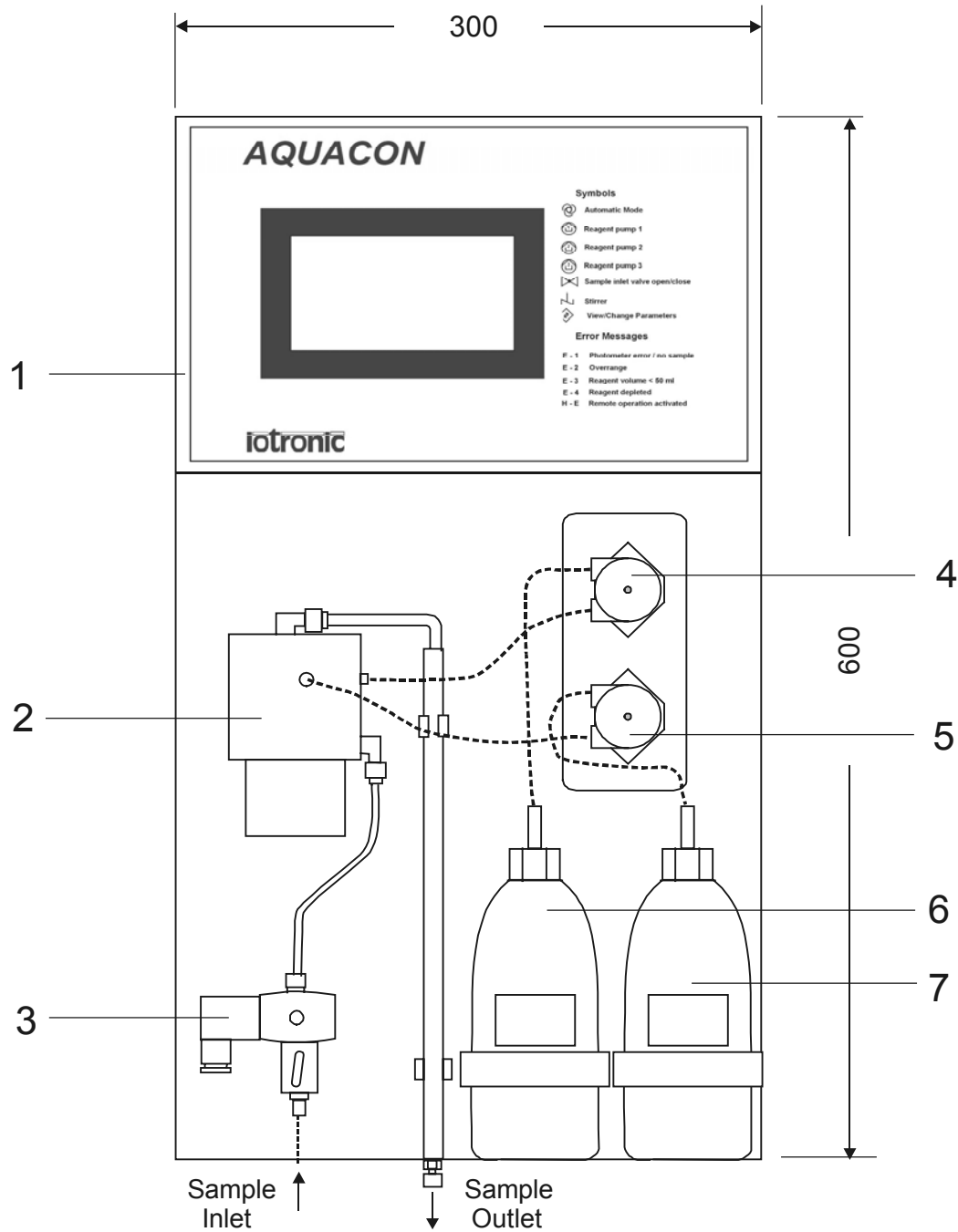





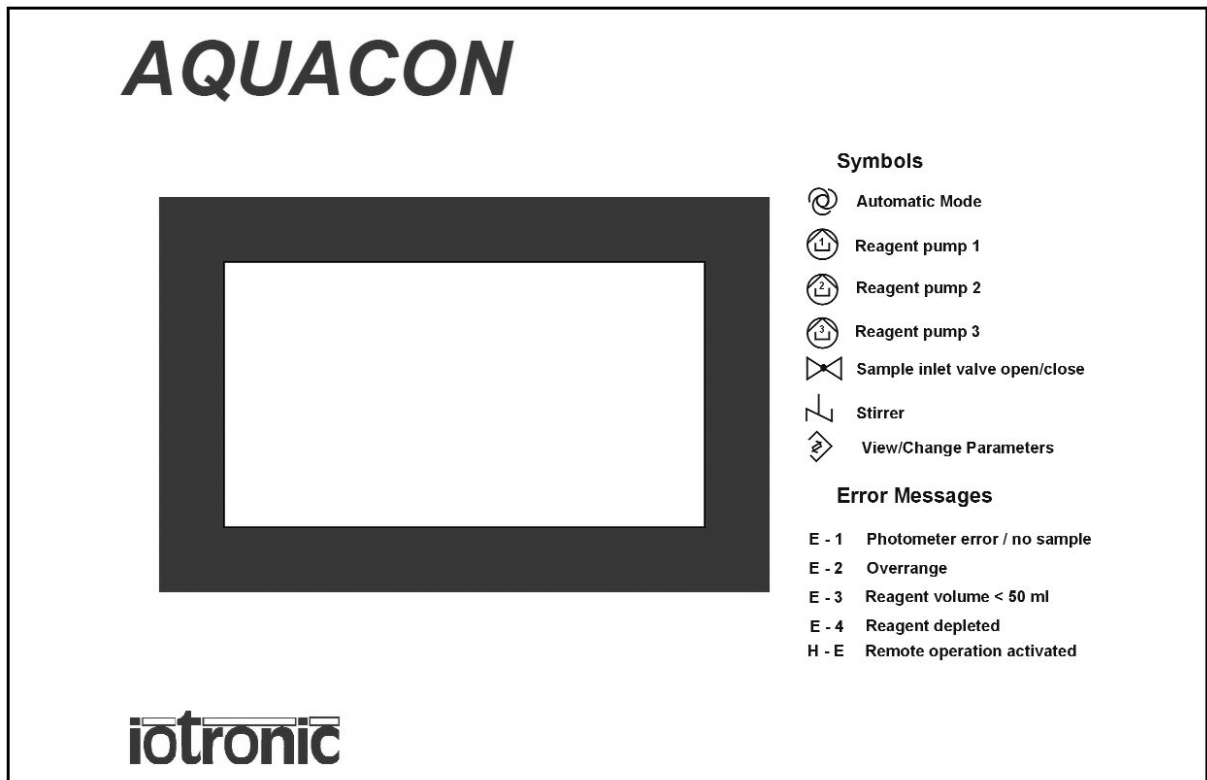

- 1 Transmitter with touchscreen
- 2 Measuring chamber
- 3 Sample inlet valve
- 4 Stepping motor unit with tube pump
- 5 Tube pump for buffering or cleaning solution (optional)
- 6 Reagent vessel for hardness reagent (500 ml)
- 7 Reagent vessel for buffering or cleaning solution (optional)

**AQUACON RH Display and Keyboard**



**Explanation of Symbols**

Symbol	Function
	Select Automatic Mode, start an analysis
	Reagent pump 1 on/off
	Reagent pump 2 on/off (optional)
	Sample inlet valve open/close
	Stirrer on/off
	View / Change parameters



### **3.1 Analytical Part**

The transmitter of the process titrator AQUACON RH is contained in a compact housing and includes the microprocessor which recognizes the colour end-point of then titration, displays the final calculated result and controls the operation of the process titrator with respect to sampling, rinsing of the measurement chamber, dosing of the reagent and surveillance of the photodetection system.

### **3.2 Measurement and Control**

The user may set a freely-programmable maximum limit of the measured value, which, when exceeded, will activate a relay contact which is found on the connection terminal rail (see chapter 3.6.1). In addition, a 0/4 - 20 mA current output delivers a signal proportional to the measured values (see chapter 9.1). The start and end of output range are freely programmable (see chapter 3.6.3).

All user-defined settings are maintained during power failure to the instrument.

### **3.3 Operation and Measurement Security**

When the end-user defined maximum alarm value is exceeded or when an error occurs (ERROR E-1 to ERROR E-4) the alarm relay will activate.

The actual reagent volume of reagent 1 is calculated by the microprocessor and is corrected for usage after each analysis. Once the calculated remaining reagent volume falls below the factory-predetermined value of 50 ml, an alarm message (ERROR E-3) is displayed on the touchscreen and the alarm relay (found on the transmitter terminal connector) is activated. The remaining 50 ml reagent is sufficient for approximately:

**RH:** 240 analyses with a total hardness of 1,8 ppm CaCO<sub>3</sub> (0,1 °dH)

per analyses. Should this alarm be ignored and the reagent is depleted, a second alarm message (ERROR E-4) and relay activation is initiated by the process titrator and the process titrator stops.

The optical transparency of the measurement cuvette is measured at the start of each analysis. An automatic zero adjustment takes place before each measurement to compensate for colored or turbid samples or for discoloration/contamination of the cuvette windows. Once the factory-predetermined limit to the zero adjustment is exceeded, another alarm message (ERROR E-1) is displayed on the touchscreen, the alarm relay is activated and the analysis cycle is interrupted.

In the event of sample failure, the titrator will detect this and display the alarm message ERROR E-1 on the touchscreen, activate the alarm relay and interrupt the measurement.

When the sample interval defined by the end-user has elapsed, the process titrator will automatically resume measurement as normal and repeat the procedure until sample flow is reestablished.

The analysis cycle may be interrupted by touching the button “Hand” or the button “Param” on the touchscreen.

The process titrator remains in manual operation mode until the automatic mode is selected by pressing the appropriate symbol or touch button.

### **3.4 Automatic Operation**

The process titrator will automatically carry out an analysis once the automatic function key is pressed. On the return of power to the instrument following a power failure, the process titrator will automatically enter the automatic mode and starts a measurement. This is displayed as state “MEASURING”. On the touchscreen, the last actual measured value of analysis is displayed. If the result of analysis is below the lower measuring limit, the display shows ”0,00 °dH”.

Under the last measured value, the set parameters for “Limit value” and for “Alarm value” are displayed. This values can be parametrized by the end-user (see chapter 3.6).

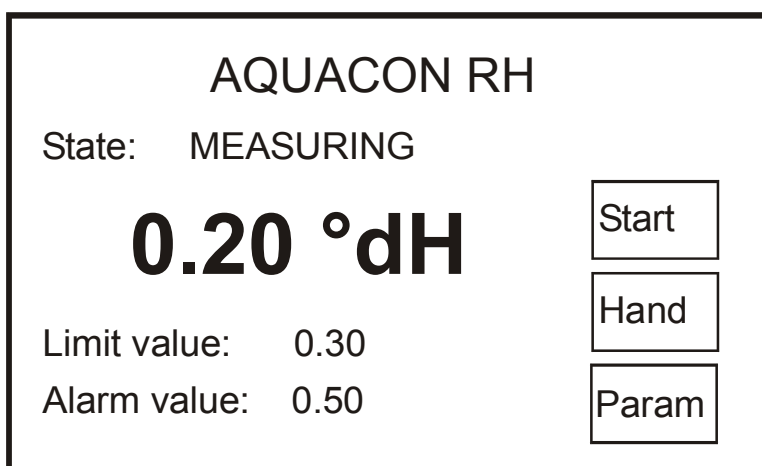

The automatic analysis cycle can be interrupted at any stage by touching the button “Hand” or the button “Param” on the touchscreen (see chapter 3.5).

**When the upper measurement range is exceeded, the alarm message „ERROR E-2“ is displayed on the touchscreen and the alarm relay is activated.**

#### **CAUTION:**

The upper limit of measurement range of the process titrator AQUACON RH is 0,5 ° dH. Avoid under any circumstances to measure water with a hardness > 5 ° dH, because wrong measurement values can result from precipitations. If water with hardness > 5 ° dH was analysed it is recommended to clean the measurement chamber with diluted hydrochloric acid.

### 3.5 Manual Operation

Manual operation of the process titrator is useful for maintenance, commissioning of the analyzer and when correction of alarm conditions during normal operation occur.

Manual operation of the process titrator is effected by pressing the button “Hand” on the touchscreen. During the internal zero adjustment of the titrator, short delays can occur. Automatic operation is interrupted and the screen displays the manual mode (state: “MANUAL”). Simultaneously, the actual absorbance (extinction) value is displayed in the upper display.

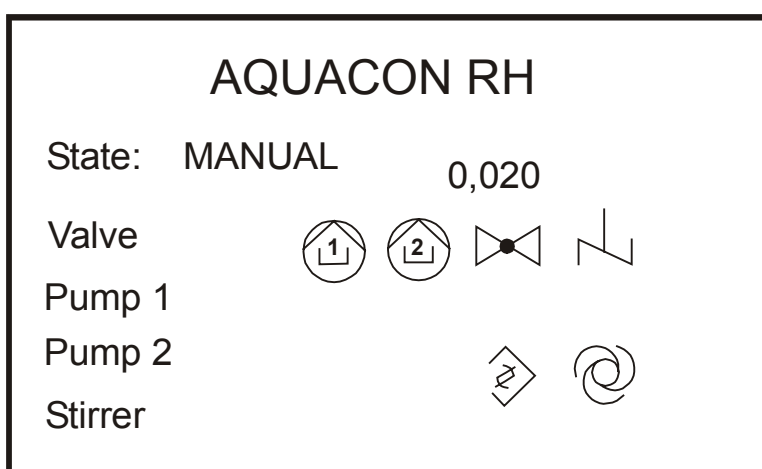

During manual operation, the pump, the sample inlet valve and the stirrer can be activated/deactivated by touching the appropriate symbols. The active part will be displayed with inverse letters.

During manual operation, the mode can be switched to automatic mode and an analysis can be started by touching the symbol .

During manual operation, the mode can be switched to parameter mode by touching the symbol .

### **3.6 Display/Set Parameters**

The parameter mode can be activated from automatic mode by touching the button “Param” or from manual mode by touching the symbol 

AQUACON RH		
Limit value:	0.30	<input type="button" value="Start"/>
Alarm value:	0.50	
Output mode:	4-20 mA	<input type="button" value="Hand"/>
Output start:	0.00	<input type="button" value="&gt;&gt;"/>
Output end:	0.50	

In parameter mode, a new screen will be displayed which shows the parameters Limit value, Alarm value, Output mode, Output start and Output end. By touching the button “ >> ” , a second screen will be displayed with the parameters Sampling interval, Calibration factor, Rinse time and Reagent volume.

AQUACON RH		
Sampling interval:	10	<input type="button" value="Start"/>
Calib. factor:	1.00	
Rinse time:	15	<input type="button" value="Hand"/>
Reagent volume:	499	<input type="button" value="&lt;&lt;"/>

By touching the button “ << ” , the first parameter screen will be displayed again.

All parameters are set to a certain value (factory settings), but can also be parametrized by the end-user (see the following chapters 3.6.1 – 3.6.7).

To change the parameters, the corresponding values must be touched. Then, a parameter specific screen opens where the new parameter values can be typed by touching of the figures (except parameter “Output mode”).

AQUACON RH

Limit value 0.30

1	2	3
4	5	6
7	8	9
	0	

Save

Clear

To leave the screen and confirm/save the new parameter value, the button “Save” must be touched. To leave the screen without saving, the button “Clear” must be touched.

### 3.6.1 Limit Value

The limit relay will activate when the end-user defined maximum limit value is exceeded. The titration will be continued until the titration endpoint (colour change). The factory-predetermined limit is set to 0,30 ° dH (RH). A value between 0 and 9.99 ° dH (RH) may be chosen, but only values lower than the upper measurement range are useful.

### 3.6.2 Alarm value

The alarm value is factory-predetermined to the upper measurement range 0,50 ° dH (RH). The alarm relay will activate when the end-user defined maximum alarm value is exceeded and an error message is shown on the touchscreen. A value between 0 and 9.99 ° dH (RH) may be chosen, but only values lower than the upper measurement range are useful.

#### **CAUTION:**

When the alarm value is exceeded the process titrator AQUACON RH interrupts the analysis cycle and an alarm message appears. If the limit value is higher than the alarm value the limit relay is not activated.

### **3.6.3 Analog Output setting (mode, start value and end value)**

An analog current signal (0/4 - 20 mA), proportional to the measurement value, may be directed from the AQUACON process titrator to remote recording/controlling devices. The mode, the start value and the end value of the analog output can be parametrized by the end-user.

The mode of the analog output can be switched from 0-20 mA to 4-20 mA by touching of the corresponding value on the touchscreen.

A value between 0 and 9.99 ° dH (RH) may be chosen. The set end value must be higher than the set start value.

### **3.6.4 Sample Interval**

The sampling interval between two automatically initiated samples may be programmed. The factory-predetermined sample interval is set to 10 min. A value between 1 and 99 min. may be chosen.

### **3.6.5 Titer/Calibration Factor**

The process titrator may be recalibrated from time to time by entering a titer/calibration factor (see chapter 5.5). A value between 0.00 and 9.99 may be chosen.

### **3.6.6 Rinsing Time**

The measuring chamber is rinsed for 15 seconds before an analysis takes place. The preset rinsing time may be altered by the end-user. A value between 15 and 99 seconds may be chosen.

Depending on the length of the sample inlet tube and the water flow rate, the rinsing time should be long enough to flush the sample lines and fill the measuring cuvette with fresh sample. A tube length of max. 5 m is recommended between sample valve and the analyzer.

### **3.6.7 Reagent Volume**

The remaining reagent volume is calculated and stored in memory by the microprocessor. When the reagent is replaced, the reagent volume of the new reagent bottle or a value between 0 and 999 should be chosen.

The automatic operation mode starts when the button “Start” is touched.

## 4 Switching Functions of the Process titrator

### 4.1 External Switching

The process titrator AQUACON RH has a potential-free input contact which may be used to control the instrument from a remote position/device. When the input contact is closed the process titrator will automatically carry out an analysis, when the input contact is open the process titrator completes the actual analysis and stops.

When the limit relay is activated and the process titrator is stopped by a remote position/device the limit relay will be inactivated after 15 minutes.

The process analyzer is delivered with bridged external switching contact into female. For using external switching contact remove this bridge! During the interval between two analyses the process titrator may be activated by a short off/on impulse of the external contact.

### 4.2 Display in the standby mode:

In the standby mode the display will show „H-E“ and the last measured value (the value that was determined in that analysis before that one that was terminated by opening the external contact).

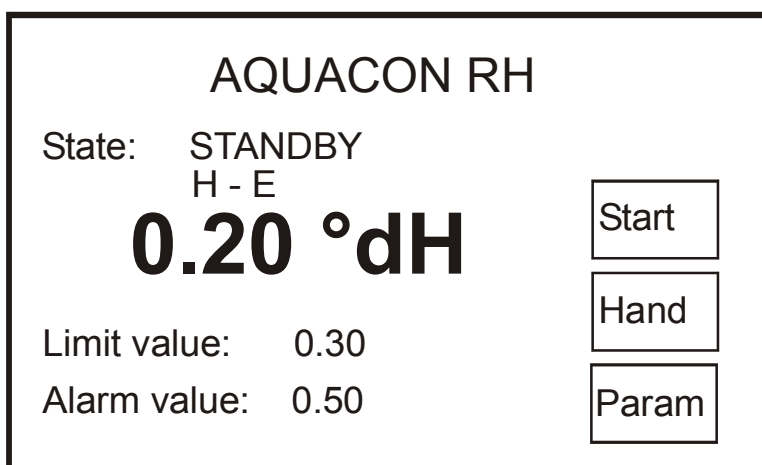

When an error message occurs this will be displayed additional to “H-E”.

### 4.3 Analysis state relay

The analysis state relay K 1 is activated during the time when the analyzer operates an analysis.

#### **4.4 Limit Value Relay**

The potential-free limit value K 2 relay is activated when the end-user defined limit is exceeded.

During the automatic operation mode, "limit value" will be displayed when the measurement results are higher than the set limit value.

#### **4.5 Alarm Limit Relay**

The potential-free alarm relay is activated when an alarm is exceeded within the process titrator. The alarm is caused by an error in the optical system, when the measurement range is exceeded or when the reagent volume falls below than 50 ml. The appropriate alarm message will be displayed as "ERROR E-1, ERROR E-2, ERROR E-3" or "ERROR E-4" (see chapter 3.3).

#### **4.6 Current Output**

The process titrator delivers a current output, 0 or 4 to 20 mA, which is proportional to the measurement range selected by the end-user (see chapter 9.1). This current output may be used as input to remote recording devices, for data processing, controlling functions etc. The current output is independent of resistance load up to a value of 500 ohm. The start and end value of the current output signal may be set by the user within the measurement range.



**Don't connect any external voltage to the connections of the current output. Failure to observe this information could result in damage to the equipment.**

See above, " 3.6.3 Setting the Analog Output". To avoid resolution losses of the current output signal the user defined measuring range should be > 6 % of the total measurement range. The start value should be lower than the end value and vice versa. Setting the start value higher than end value results in a constant output of 20 mA. Similarly, setting the end value lower than that of the start value results in a constant 0 or 4 mA output.



## 5 Start-up and Maintenance Instructions

### CAUTION:





As soon as the analyzer is connected to the main supply, automatic operation commences. This is required for automatic restart of the analyzer in the event of a power failure. At start-up, it is necessary to access the Manual Operating mode by touching the “Hand” button as soon as the analyzer is connected to main supply and is operational.

### 5.1 Connection of sample water

1. Connect inlet and outlet connectors (6/4; 8/6) max. length 5 m
2. Connect power supply to device  
**Caution:** see label on the housing for specified voltage
3. Select the sample inlet valve to „open“ (press button  on the touchscreen)
4. Carefully open the manually-operated valve beneath the solenoid operated valve to set the sample flow (20-30 l/h)

**Caution:** Maximum sample pressure 10 bar!

### 5.2 Connection of reagent, bleeding of pumps and tubes

1. Open the reagent vessel top. Ensure that the pump tube is installed and the pump head is screwed down.
2. Switch on the stirrer (button ) and the first pump (button ) in order to fill the suction-lances and pressure-tubes (Sign: the extinction in the display is rising).
3. After filling the tubes switch off the pump and stirrer.
4. If there is a second or third reagent available, repeat step 1-3 with this reagents.
5. Rinse the measuring chamber by activating the sample inlet valve (button ) and stirrer (button ) in order to wash out the reagent entered while filling the tubes
6. Select automatic operation (button ). The device now operates in automatic mode and start the measurement.

**Perform 2 to 3 analyses. Regard correct filling by observing the measurement outlet tube with the selected sample flow conditions. When satisfied that the system is performing correctly, the parameter settings may be carried out prior to automatic operation**

### 5.3 Replenishment of Reagent

The reagent bottle may be replaced, after setting the analyzer to manual mode. Now the volume of reagent must be entered in „Param“ mode step to 250 (if the volume of reagent 1 is 250 ml) or to 500 (if the volume of reagent 1 is 500 ml). See also chapter 3.6.7.

Important: The handling with chemical standards and reagents can be dangerous. Before the reagent bottles are connected or replaced, it is necessary to read their specific MSDS (material safety data sheets).

### 5.4 Changing of Tube box

Replacement of the complete tube-box by pressing the brackets at the sides, take off the old box and give up a new box.

**Important:**

**All tube boxes must be replaced after consumption of 5 bottles reagent or latest after 6 months.**

### **5.5 Recalibration of the Process analyzer**

Under normal conditions, a re-calibration of the process analyzer is not required since the reagent to sample ratio have been correctly determined at the time of manufacture. However should the need arise to verify the process analyzer, a standard solution may be introduced. In the unlikely event of a deviation from the introduced standard (incorrect reagent strength, pump tube aging, incorrect pump tube, contaminated measuring cell), a titer/calibration factor may be calculated as follows:

$$\text{titer/calibration factor} = \text{Standard solution value} : \text{Measured value}$$

Should the titer/calibration factor deviate by more than 20 % from 1, then a change of the tube box or a cleaning of the measurement chamber is maybe necessary.

### **5.6 Maintenance interval**

A maintenance of the analyzer should be made after 5 consumed reagent bottles or latest after 6 month. A maintenance should include at least an optical control of the analyser, a function control and a change of the tube boxes. If necessary, the maintenance should also include a cleaning of the measurement chamber and of the injectors for the tube connection at the measurement chamber.

### **5.7 Shut down procedure**

If the analyzer is shut down for an extended period of time, all reagents and samples should be removed out of tubings and the measurement chamber, and all tubings and the measurement chamber should be cleaned and flushed with deionized water.

## 6 Alarm Messages

Message in display	Description	ACTION
ERROR E -1	Error in the optical system; the analyzer operation is interrupted: - contaminated cuvette windows - defective liRHt source - defective photodetector - no sample ( <b>NB Most likely cause of failure!</b> )	<b>Check sample inlet valve, clean the measuring chamber, call maintenance service.</b>
ERROR E -2	Measurement range exceeded	<b>Verify if residual hardness is too high. Check stirrer function.</b>
ERROR E - 3	Reagent volume has dropped below the factory preset value of 50 ml. The operation of the analyzer remains unaffected until reagent is depleted.	<b>Replace reagent soon.</b>
ERROR E - 4	Reagent depleted. The analyzer results are no longer valid.	<b>Replace reagent.</b>
H -E	Remote operation activated	

## 7 Technical Data

Current output	0/4 - 20 mA, max. load 500 ohm
Display	240 x 128 dots, Touchscreen
Relays	1 x Alarm, potential-free 230 V/50 Hz, 3A 1 x Limit, potential-free 230 V/50 Hz, 3A 1 x Analysis state, potential-free 230 V/50 Hz, 3A
External Switching	potential-free contact, 18 V DC, ca. 4 mA
Power Supply	110 - 230 V -- 50/ 60 Hz
Power Consumption	approx. 16 VA
Dimensions	640 x 315 x 190 mm (H x W x D)
Protection	IP 65 (transmitter housing)
Connections	Plugs with circular connection 1,5 mm <sup>2</sup>
Temperature	5° to 45°C, at consumption of reagents within 6 months

**Since it is company policy to continuously improve its product range, we reserve the right to make changes in the product design without notification to its users**

## 8 Specifications

Parameter	Hardness
<b>Description</b>	Microprocessor-controlled analyzer for the determination of residual hardness in water <b>AQUACON RH</b>
<b>Typical Applications</b>	Monitoring and control of water softening plants
<b>Method of working</b>	Complexiometric titration of the total hardness using a combined reagent, comprising titer and hardness indicator
<b>Measuring Range</b>	0,02 – 0,50 ° dH
<b>Resolution</b>	0,01 ° dH
<b>Accuracy</b>	5 % of end value
<b>Reproducibility</b>	3 % of end value
<b>Zero-point Stability</b>	automatic adjustment
<b>Number of samples</b>	1
<b>Sample</b> Operating Pressure Temperature Sample Volume Sample Condition Chemical Demands Drain	0,1 - 10 bar 5 - 30 °C 25 ml/analysis (excluding rinsing volume) clear, with particles < 0,5 g/l ; < 50 µm pH 4 - 10, Fe < 3 ppm, Cu < 0,2 ppm, CO <sub>3</sub> <sup>2-</sup> < 10 mmol/L pressure free into open drain
<b>Reagents</b> Number Storage Temperature Usage/analysis/1,8 ppm Reagent volume	1 (optional 2) 5 – 20 °C 0.21 ml 500 ml
Suitable for analysis (approx.) (at hardness level of)	2300 (0,1 ° dH)
<b>Analysis</b> Cycle (approx.) Sample interval	3 – 15 min., including rinsing, dependent on hardness 1 min - 99 min
<b>Option</b> 2 <sup>nd</sup> pump	For cleaning or buffering solution

## 9 Connection Diagram

### 9.1 Set 0/4 - 20 mA-Output

The 0/4 – 20 mA output can be set by changing the appropriate parameters (see chapter 3.6.3).

## 9.2 Connections

In – and outputs are available at circular connectors at the top of the device.

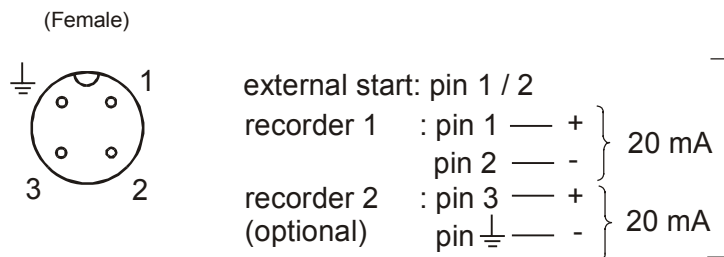
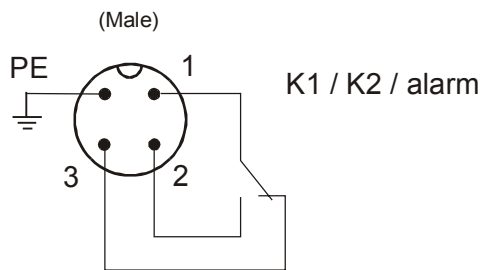
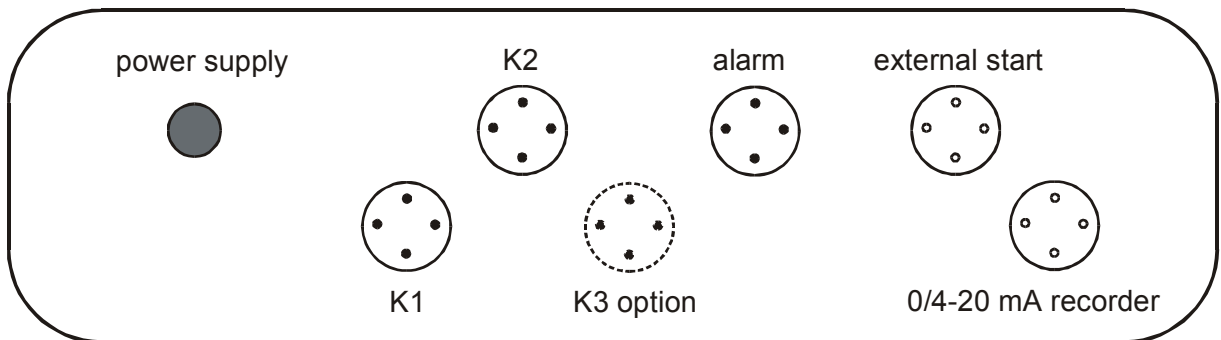

**caution !**  
 do not connect any voltage  
 to these terminals



### **CAUTION: technical data !**

power supply	Power supply (110 - 230 V, 50/60 Hz)	PE	protection earth
K1	Analysis status signal	K2	Limit value relay 1
external start	potential-free input contact	alarm	alarm limit relay
20 mA Output 1	0/4 - 20 mA output (max. load 500 Ω)	K3	Limit value relay 2 (optional)

### **9.3 Installation**



## **WARNING**

**Only Qualified Personnel !**

**Only Specified Power Supply !**

See required power supply as noted on instrument.

**Observe local regulations!**







Install a power supply that can be disconnected (plug, switch).

Take care for use of the protective covers for not used connectors.

Do not install measuring-or control cables in parallel or close distance in the same cable guide with power supply.

## 10 Appendix

### 10.1 Analysis cycle

Length	Operation				
15 -99 s	Rinsing of the measurement chamber		X		
1 s	Buffering the sample (optional)				X
10 s	Sample degasification	X			
~ 40 s	Automatic zero adjustment				
1 imp	Buffering the sample	X		X	
12 s	Waiting	X			
4 s	Measuring				
~ 7 - 660 s	Titration	X		X	
20 s	Rinsing of the measurement chamber	X	X		
1 s	Injection of cleaning agent (optional)	X			X
1 - 99 min.	Break time				

**10.2 Spare part and consumable item list**

Consumable item	Term	Quantity	Order No
Indicator solution AQUACON RH	RH-B2300	500 ml	101 2705 01
Buffering solution (optional)	Pufferr. 1	500 ml	101 2705 03
Tube-Box	SMK10	1 piece	121 0036 01
Tube-Box for cleaning solution	SK10	1 piece	121 0037 01
spare parts			Order No
Sample connection tube	CF16	1 m	121 0015 01
Transmission pressure tubing	PT10	1 m	121 0014 01
Stepping motor unit	SM10	1 piece	121 0006 01
Tube pump for buffer reagent (Option)	SP10-2	1 piece	121 0008 02
Solenoid valve type 1 2/2 way (brass)	MV01-G	1 piece	121 0004 02
Magnetic stirring bar for measuring chamber			121 0044 01
Glass measuring cuvette			121 0045 01

Basic equipment of consumables are included in price



## 11 Troubleshooting Guide

Problem	Reason
On pressing the „automatic operation“ key switch, the analyser does not enter automatic analysis cycle.	<ul style="list-style-type: none"> <li>• The contact bridge for external switch function (see 4.1) is not installed or has no contact switch. „H-E“ appears in the display. <b>Solution:</b> install bridge</li> <li>• The measurement chamber is empty (i.e. no sample) or the sample is strongly coloured or contaminated. „ERROR E-1“ appears in the display. The analyser will automatically reenter the measurement cycle following the sample interval and reset the alarm <b>Solution:</b> clean the measurement cuvette with 10% hydrochloric acid, check sample flow, check optical components (open measurement chamber and set analyser to manual operation. The displayed absorption should increase when the optical path is restricted by an opaque object)</li> <li>• Reagent is depleted or incorrect reagent volume entered. „ERROR E-4“ appears in the display. <b>Solution:</b> Replace reagent if depleted and reset reagent volume to the correct volume via parameter input..</li> </ul>
The analyser continuously displays setpoint overrange	<ul style="list-style-type: none"> <li>• The setpoint selected is below the measured value. „ERROR E-2“ appears in the display. <b>Solution:</b> Verify the measured value by alternative analysis Increase setpoint value</li> </ul>
The values displayed are erratic even though the actual measured variable is constant	<ul style="list-style-type: none"> <li>• Reagent container is not opened to atmosphere. Vacuum drawn on the reagent vessel. <b>Solution:</b> Open the reagent bottle cap to release vacuum. Do not retighten.</li> <li>• Magnetic stirrer immobilised <b>Solution:</b> Open the measurement cuvette. Stirrer is switched on by manual operation. Check that the magnetic follower is not jammed by loosening gently with a glass stirring rod. Increase the motor voltage by adjusting the appropriate potentiometer in the terminal box. If the problem is not rectified, call Service.</li> <li>• Reagent tubing is kinked or the feed tube in the reagent container is pushed against the bottom of the vessel. <b>Solution:</b> Straighten all tubes and tilt feed tube away from the bottom of the reagent container</li> <li>• Sample pressure is too low to effectively flush the measuring cuvette after analysis The cuvette does not overflow or overflows very slowly during flushing cycle. <b>Solution:</b> Increase the sample pressure to above 0.1 bar. Open sample inlet needle valve to allow 100 - 200 ml water flow per analysis cycle..</li> </ul>
A calibration factor differing widely from 1.00 must be used to achieve correct results	<ul style="list-style-type: none"> <li>• Reagent is contaminated, reagent is aged, pump tube has exceeded. <b>Solution:</b> replace reagent; replace pump tubing.</li> </ul>
Pumps or solenoid operated valves do not operate in manual mode	<ul style="list-style-type: none"> <li>• a limited number of electromechanical drives may be simultaneously selected to prevent electrical overload. <b>Solution:</b> Switch off other electromechanical drives and try again.</li> </ul>